

# focus

## TECHNICAL DATASHEET

# E300

**FOCUS LIMITOR/E-Series**  
**On/Off Multi-Turn Electric Actuator**

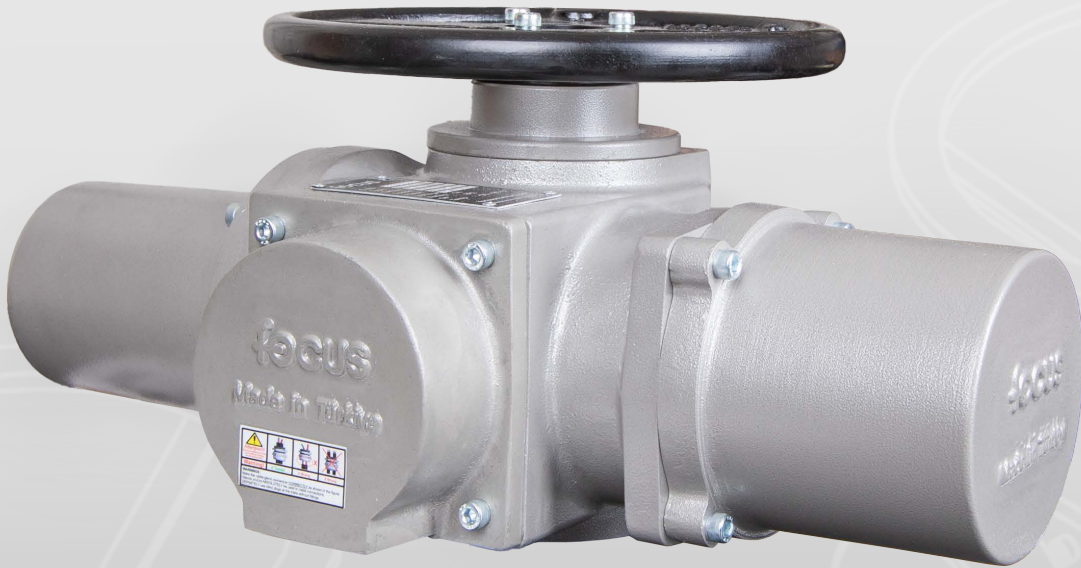

**Headquart**  
Mutlukent Mahallesi,  
2016/1 Sokak, No:32  
Çankaya, Ankara|Türkiye

+90 312 286 0906  
sales@denz.co

**Factory**  
Ivedik OSB 1354.  
Cadde 1357,Sokak No:38  
Ankara|Türkiye



# E300

**380-400V, 3pH, 50Hz  
Multi-Turn, On/Off**

## General features:

- Type: E300
- Operation: Only remote
- Position Control: Limit & torque switches
- 2 Limit and 2 torque switches
- S4-25% minutes duty
- 1-3 Phase, 220/380-400V, 50Hz
- Torque: 300 N/m
- Output Speed: 36 RPM
- Motor Power: 1,5 kW
- Insulation: Class H
- Enclosure: IP68
- Motor protection: Thermo switches (PTC)
- Flange-Gearbox Connection: ISO 5210 F14
- Coupling: B4
- Hand-wheel for emergency situations
- Main pin connector (easy electric connection)
- Motor pin connector (easy maintenance)
- Control unit pin connection (modular design, easily attach a Matic unit later on)
- Full cast aluminum body
- Auto-lock system
- Maximum stem diameter (for valves): 35mm
- Maximum stem diameter (for penstocks): 50mm
- Easy switch settings

## Alternative or additional features (might cause price difference)

- 4-20 mA transmitter
- 4-20 mA positioner
- Mechanical position indicator
- Non-Instructive switch
- Output speed : 72 Rpm
- Coupling :A-Type coupling (unmanchiened)

*Additional notes ( if any):*

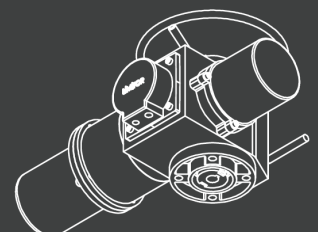
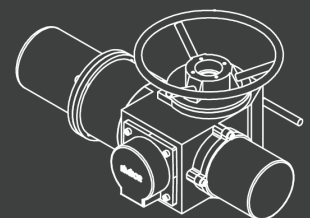
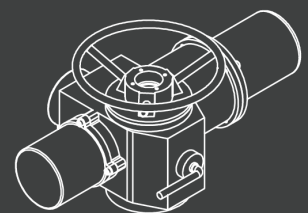
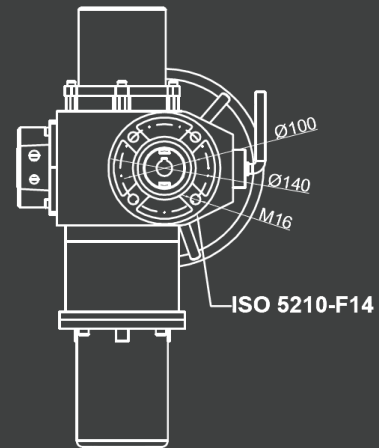
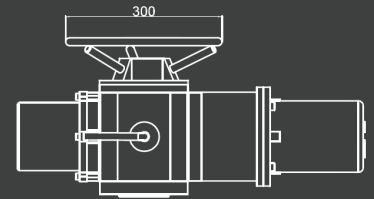
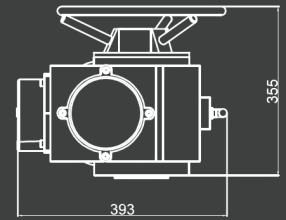
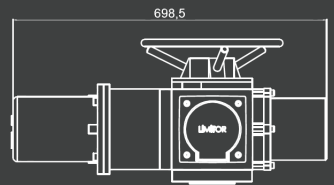

# WIRING DIAGRAM

## E300

220/380-400V, 1-3pH,  
50Hz Multi -Turn

