

focus

TECHNICAL DATASHEET

E120&ICU+

FOCUS LIMITOR/E-Series
Modulating Multi-Turn Electric Actuator



Headquarter
Mutlukent Mahallesi,
2016/1 Sokak, No:32
Çankaya, Ankara|Türkiye

+90 312 286 0906
sales@denz.co

Factory
Ivedik OSB 1354.
Cadde 1357, Sokak No:38
Ankara|Türkiye



E120&ICU+

220/380-400V, 1-3pH, 50Hz
Multi-Turn, Modulating
Integral Control Unit+(ICU+)

General features:

- Type: E120&ICU+
- Operation: Remote and local (ICU+)
- Position Control: Limit & torque switches
- 2 Limit and 2 torque switches
- S4-25% duty
- 1-3 Phase, 220/380-400VAC, 50Hz
- Torque: 120 N/m
- Output Speed: 38 Rpm
- Motor Power: 0,75 kW
- Insulation: Class H
- Enclosure: IP68
- Motor Protection: Thermo switches (PTC)
- Flange-Gearbox Connection: ISO 5210 F10
- Coupling: B4
- Hand-wheel for emergency situations
- Main pin connector (easy electric connection)
- Motor pin connector (easy maintenance)
- Control unit pin connection (modular design, easily remove ICU+ later on)
- Full cast aluminum body
- Auto-lock system
- Maximum stem diameter (for valves): 25mm
- Maximum stem diameter (for penstocks): 40mm
- Easy switch settings

ICU features:

- LCD Display, English and user-friendly
- Interface Local-Remote switch
- Configuration buttons (Open, Stop, Close)
- LED Indication lights (Open switch, close switch, open torque, close torque)
- General fault indicator
- Reversing control (Automatically correct the phases)
- Transmitter & Positioner
- Programmable behavior on loss of signal
- Analogue output signal as 4-20 mA

Alternative or additional features (might cause price difference)

- Wall mounting bracket
- Modbus
- Profibus
- Non-Instructive switch
- Output speed: 76 Rpm
- Coupling: A-Type coupling (unmachnied)
- 220V
- Bluetooth

Additional notes (if any):

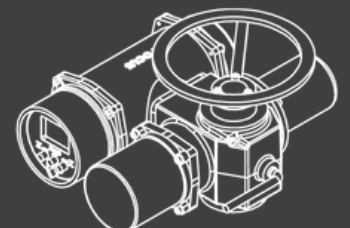
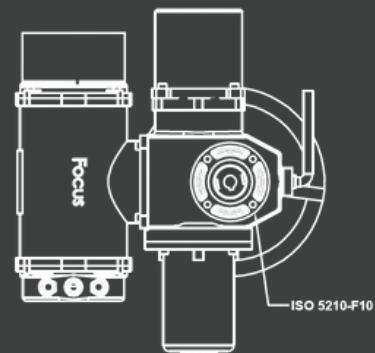
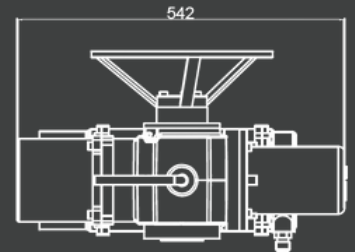
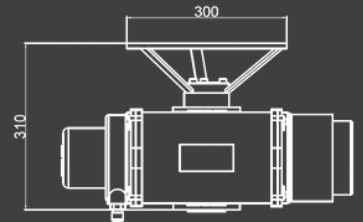
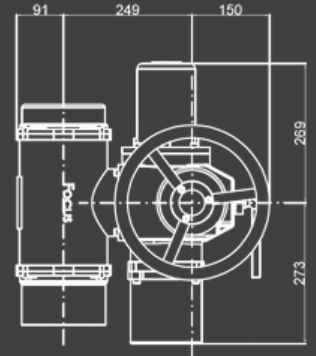
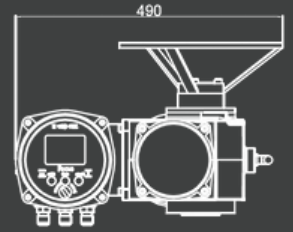

WIRING DIAGRAM

E120&ICU+

220/380-400V, 1-3pH, 50Hz
Multi -Turn

