



C21 Flap Valve

Product Description

DENZ-C21 Flap Check Valves also known as Flap Gates are put on the end of a flanged pipe to allow the flow of water out of the pipe, but prevent anything from flowing back in, such as sticks, leaves or other debris.

Operation

When properly installed, the flap valve will swing open under direct pressure to release the outfall fluid and close when the direct pressure is relieved. DENZ C21 Flap Valve has a 10-degree inclined seating plane to ensure positive seating.

Maintenance

Periodic inspection is recommended to determine that the flap disc remains free to swing open and that the bronze seats have not been damaged.

Installation

Valve must be installed so that the bolt holes in the flange (125-lb. template) straddle the vertical center line. See drawing for diameter and quantity required.

Parts

Parts are available by request. Please contact DENZ sales department for more information.

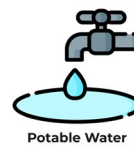



Material List <<<<

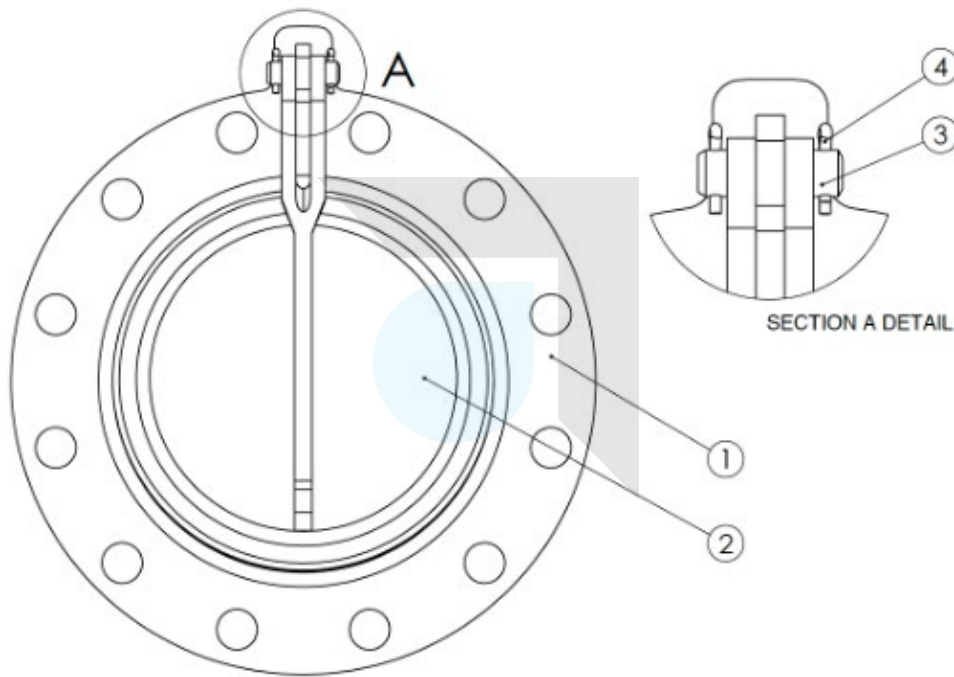

#	Part	Material
1	Body	Steel / Ductile Iron
2	Disc	Steel / Ductile Iron
3	Pin	Stainless Steel A2
4	Cotter Pin	Stainless Steel A2



Dimensions

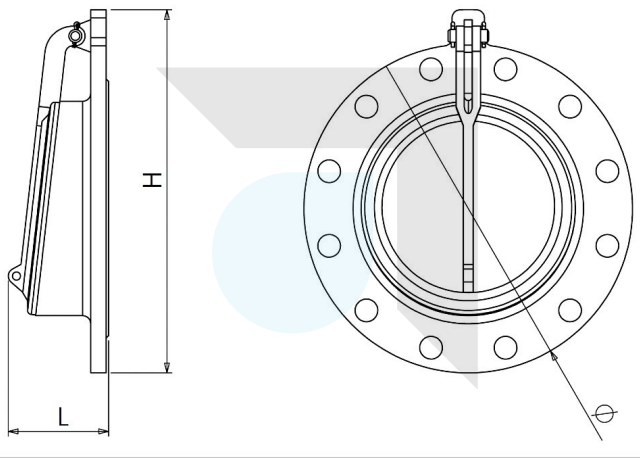

DN	PN	ø	L	H	KG
80	10	200	100	216	12
	16	200			12
	25	200			12
	40	200			12
100	10	220	100	240	12
	16	220			12
	25	235			12
	40	235			12
125	10	250	100	275	14
	16	250			14
	25	270			14
	40	270			14
150	10	285	100	315	14
	16	285			14
	25	300			15
	40	300			15
200	10	340	100	380	16
	16	340	100	380	16
	25	360	104	400	17
	40	375	108	415	17
250	10	395	125	445	18
	16	405	125	455	18
	25	425	130	475	19
	40	450	135	500	21
300	10	445	150	515	24
	16	460	150	520	24
	25	485	156	545	25
	40	515	162	575	27
350	10	505	175	575	32
	16	520	175	590	34
	25	555	182	625	35
	40	500	189	650	37

Units: mm / indicative dimensions & weights

Dimensions

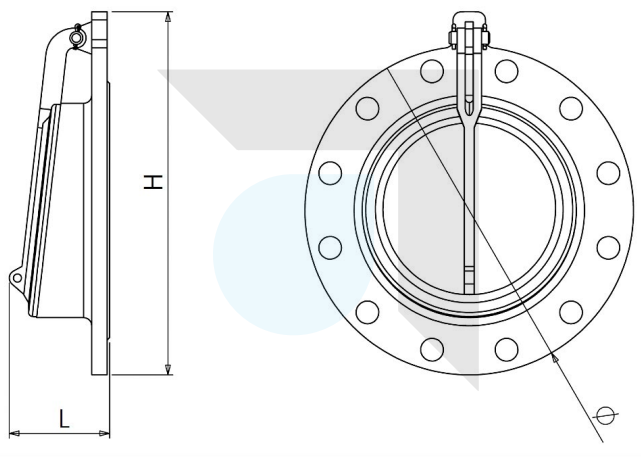

DN	PN	ø	L	H	KG
400	10	565	200	645	42
	16	580	200	660	44
	25	620	20S	700	46
	40	660	216	740	49
450	10	615	225	705	58
	16	640	225	730	60
	25	670	234	760	62
	40	685	243	775	65
500	10	670	250	770	82
	16	715	255	815	84
	25	730	265	830	86
	40	755	285	855	89
600	10	780	300	900	95
	16	840	306	960	97
	25	845	318	965	100
	40	890	342	1010	104
700	10	895	350	1035	142
	16	910	357	1050	145
	25	960	371	1100	148
	40	995	399	1135	152
800	10	1015	400	1175	200
	16	1025	40S	1185	203
	25	1085	424	1245	206
	40	1140	456	1300	210
900	10	1115	450	1295	236
	16	1125	459	1305	241
	25	1185	477	1365	249
	40	1250	513	1430	261
1000	10	1230	500	1430	283
	16	1255	510	1455	288
	25	1320	530	1520	296
	40	1360	570	1560	305

Units: mm / indicative dimensions & weights